



## OFL 280 Handheld FTTx OTDR

### Installation (Live Fiber) and Construction Models

The Noyes OFL 280 from AFL Telecommunications is a single-mode OTDR offered in two FTTx-optimized models. The 'installation and repair' model can operate at three wavelengths (1310/1550/1625 nm) on dark fibers but automatically switches to a filtered, 1625 nm only mode if a live fiber is detected. In addition, the test port is equipped with a PON power meter, which allows the OFL 280 to detect live FTTx fibers, measure FTTx network power levels, and fault-locate live FTTx fibers with a single OTDR to network connection and a single automated test. A conventional three-wavelength (1310/1490/1550 nm) 'construction' model is also available to certify or fault-locate dark fibers in FTTx or other single-mode fiber optic networks.

Both OFL 280 models can operate in Full Auto, Real-Time, or Expert (manual) modes, and offer precision event analysis, optical power meter, laser source, 12-hour battery life, internal data storage, and USB connectivity. OTDR and OPM test ports are equipped with tool-free adapters, which can be changed in seconds.

Results are saved as industry standard .SOR files, which can be transferred to a PC for viewing, printing, and analyzing with the supplied Windows® compatible software.

### Features

- Handheld, 0.8 kg (1.7 lb)
- 1.5 m dead zone (typical)
- > 28 dB dynamic range
- FTTx construction model (1310/1490/1550 nm)
- FTTx installation model (patent pending)
  - Dark fiber OTDR (1310/1550/1625 nm)
  - Live fiber OTDR (1625 nm only)
  - PON power meter (1490/1550 nm)
- OPM, OLS, and VFL (650 nm)
- 3.5-inch, indoor/outdoor LCD display
- Tool-free, switchable adapters for OTDR and OPM ports (FC, SC, ST, LC, E2000 available)
- Rechargeable Li-Ion battery (> 12 hours) or AC power
- Mini USB Port (connect to PC with cable)
- Bellcore (GR-196) .SOR file format
- Windows® compatible software

### OFL 280 Ports - FTTx Installation Model

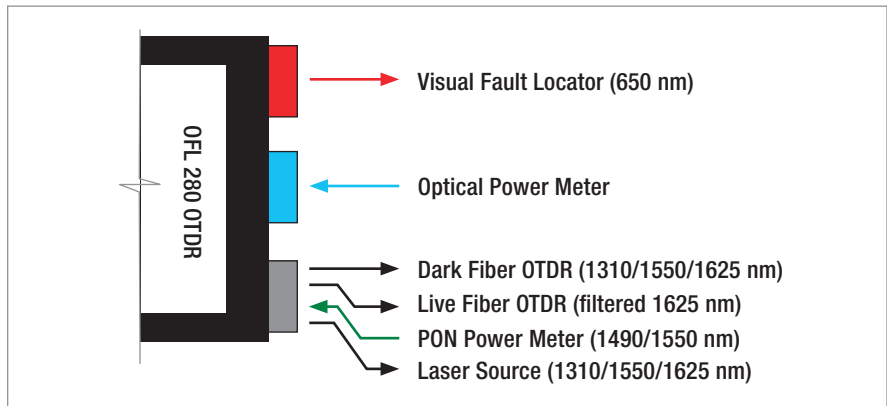

### Available Models

WAVELENGTHS	DESCRIPTION
1310, 1490, 1550 nm	FTTx construction OTDR
1310, 1550, 1625 nm (filtered)	FTTx installation (live fiber) OTDR

**Note:** All OFL 280 models come with a carry case, SC and FC adapters for the OTDR/OLS port, 2.5 mm Universal adapters for the OPM and VFL ports, USB cable (connects with normal (Type A) USB port on your PC), AC power adapter, country-specific power cord, and a user guide.



A Division of AFL Telecommunications

Continued on the next page

## OFL 280 Handheld FTTx OTDR

**Specifications** (All specifications valid at 25°C unless otherwise specified)

OTDR	
Emitter Type	Laser
Safety Class	Class I FDA 21 CFR 1040.10 and 1040.11, IEC 60825-1: 2007-03
Fiber Type	Single-mode
Available Wavelengths	1310 / 1490 / 1550 / 1625 nm
Wavelength Tolerance	± 20 / ± 20 / ± 20 / ± 10 nm
Dynamic Range (SNR=1)	> 28 dB
Event Dead Zone <sup>1</sup>	1.5 m
Attenuation Dead Zone @ 5ns <sup>2</sup>	Typical 6.0 m, maximum 6.5 m
Pulse Widths	5, 10, 30, 100, 300 ns, 1, 3, 10 μs
Range Settings	250 m to 256 km
Data Points	Up to 16,000
Data Point Spacing	12.5 cm (range ≤ 4 km), Range/16000 (range > 4 km)
Group Index of Refraction (GIR)	1.4000 to 1.6000
Distance Uncertainty (m)	± (1 + 0.005% x distance + data point spacing)
Trace File Format	Bellcore GR-196 V.1.1
Trace File Storage Medium	Internal memory (>1000 traces)
Data Transfer to PC	USB cable
OTDR Modes	Full Auto, End Locate, Expert, Live

1. Typical distance between the two points 1.5 dB down each side of a reflective spike caused by a -45 dB event using 10 ns pulse width.

2. Typical distance from event location to point where trace is within 0.5 dB of backscatter.

PON POWER METER	
Calibrated Wavelengths	1490, 1550 nm
Detector Type	InGaAs
Isolation	> 40 dB
Measurement Range	+10 to -40 dBm
Accuracy <sup>1</sup>	± 0.5 dB
Resolution	0.01 dB
Measurement Units	dBm

1. At calibration wavelengths, and power levels of approximately -5 dBm for 1550 nm and -10 dBm for 1490 nm.

OPTICAL POWER METER	
Calibrated Wavelengths	1310, 1490, 1550, 1625 nm
Detector Type	InGaAs
Measurement Range	+23 to -45 dBm
Tone Detect Range	+3 to -35 dBm
Wavelength ID Range	+3 to -35 dBm
Accuracy <sup>1</sup>	± 0.25 dB
Resolution	0.01 dB
Measurement Units	dB, dBm, μW, nW

1. At calibration wavelengths, and power level of approximately -10 dBm.

LASER SOURCE	
Emitter Type	Class I FDA 21 CFR 1040.10 and 1040.11, IEC 60825-1: 2007-03
Fiber Type	Single-mode
Available Wavelengths	1310 / 1490 / 1550 / 1625 nm
Wavelength Tolerance	± 20 / ± 20 / ± 20 / ± 10 nm
Spectral Width (FWHM)	2 nm (maximum)
Internal Modulation	1 kHz, 2 kHz
Wavelength ID (one, two, or three wavelengths)	Compatible with Noyes Optical Power Meters and Light Sources
Output Power Stability	< ± 0.25 dB after 15 min
Output Power	-3 dBm

VISUAL FAULT LOCATOR	
Emitter Type	Laser
Safety Class	Class II FDA 21 CFR 1040.10 and 1040.11, IEC 60825-1: 2007-03
Wavelength	650 nm
Output Power (nominal)	0.8 mW into SMF-28

GENERAL	
Size (in boot)	19 x 11.2 x 4.7 cm (7.5 x 4.4 x 1.9 in)
Weight	0.8 kg (1.7 lb)
Operational Temperature	-10 to +50°C, 0 to 95% RH (non-condensing)
Storage Temperature	-20 to +60°C, 0 to 95% RH (non-condensing)
Power	Rechargeable Li-Ion or AC adapter
Battery Life (backlight ON in OTDR mode)	> 12 hours
Display	LCD, 320 x 240, 3.5 inch (89 mm), color, transfective
OTDR and OPM Ports	Switchable. See web site or contact AFL for available adapter types.



A Division of AFL Telecommunications